

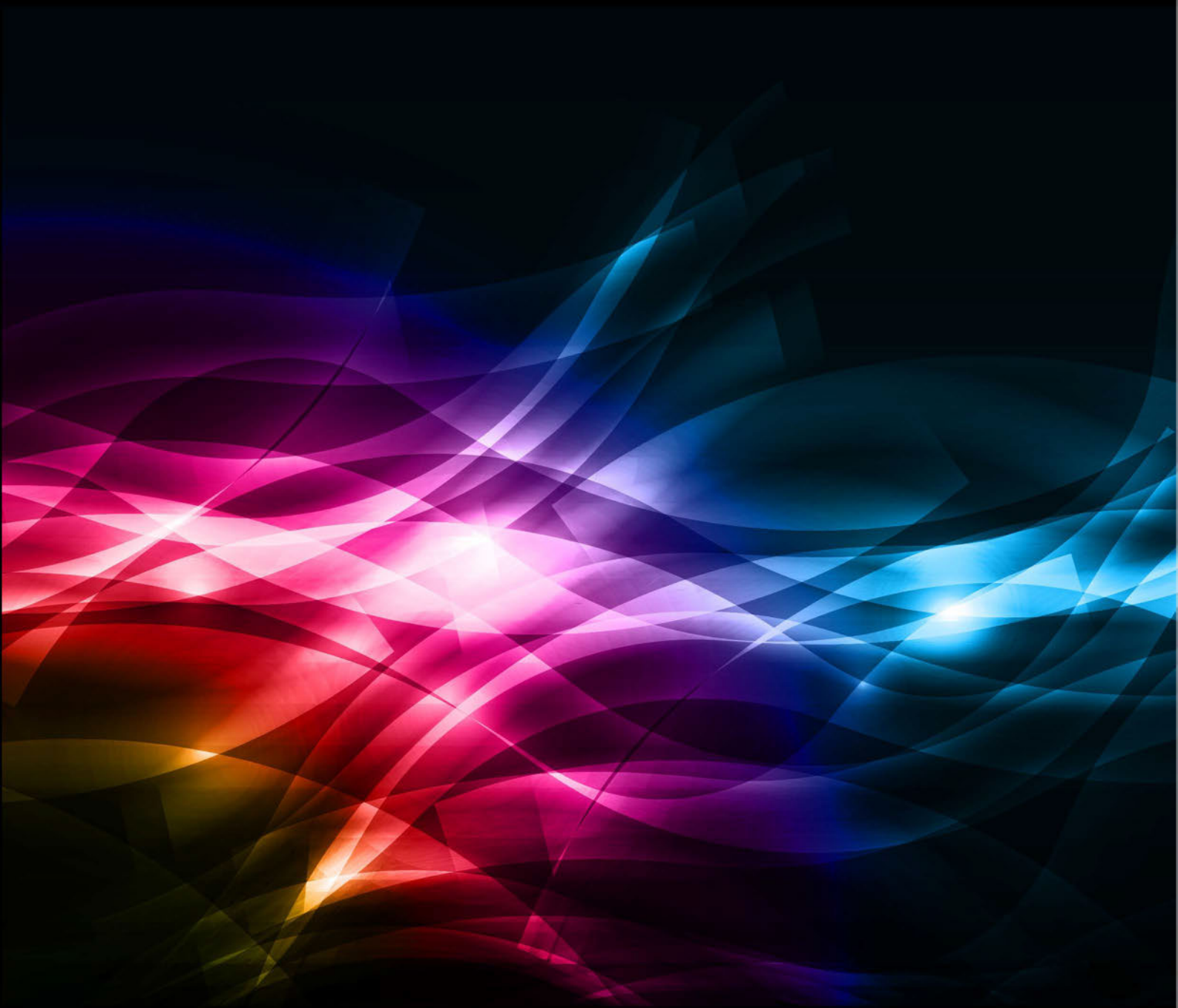

divVALI
LED LIGHTING & DESIGN



LED Corn Light



G24 2pin/4pin
21mm base



Gx24 2pin/4pin
15mm base

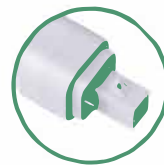

G23



E27/E26



6W



8W



12W



15W

Model No.	Power	Size	Lumen \pm 10%	CCT	Voltage	Power Factor	CRI	Net Weight
DIV-CORN-6W	6W	E27: \varnothing 35x130mm GX24: \varnothing 35x117mm G24: \varnothing 35x123mm	550lm	2700/3000/4000/5000/>6000K	AC100-277V, AC 200-240V	>0.95	\geq 83	100g
DIV-CORN-8W	8W	E27: \varnothing 35x130mm GX24: \varnothing 35x117mm G24: \varnothing 35x123mm	750lm	2700/3000/4000/5000/>6000K	AC100-277V, AC 200-240V	>0.95	\geq 83	100g
DIV-CORN-12W	12W	E27: \varnothing 35x162mm GX24: \varnothing 35x149mm G24: \varnothing 33x155mm	1100lm	2700/3000/4000/5000/>6000K	AC100-277V, AC 200-240V	>0.95	\geq 83	160g
DIV-CORN-15W	15W	E27: \varnothing 35x162mm GX24: \varnothing 35x168mm G24: \varnothing 35x175mm	1450lm	2700/3000/4000/5000/>6000K	AC100-277V, AC 200-240V	>0.95	\geq 83	160g

LED Corn Light

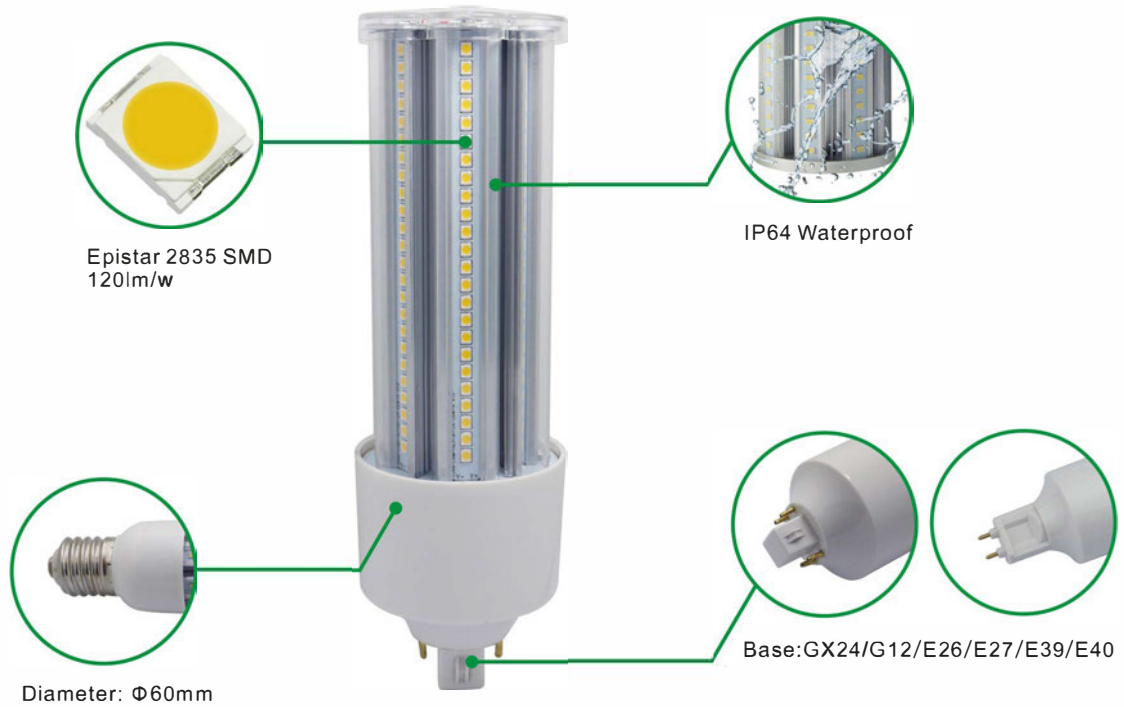

16W



20W



24W

Model No.	Power	Size	Lumen ± 10%	CCT	Voltage	Base	Power Factor	CRI	Net Weight
DIV-CORN-16W	16W	Φ60 x H167 mm	1920lm	2700/3000/4000/5000/>6000K	AC100-277V	E27/E40/GX24/G12	>0.95	≥83	280g
DIV-CORN-20W	20W	Φ60 x H187 mm	2400lm	2700/3000/4000/5000/>6000K	AC100-277V	E27/E40/GX24/G12	>0.95	≥83	290g
DIV-CORN-24W	24W	Φ60 x H207 mm	2800lm	2700/3000/4000/5000/>6000K	AC100-277V	E27/E40/GX24/G12	>0.95	≥83	300g

LED Corn Light



27W

36W

45W

54W

60W

Model No.	Power	Size	Lumen ± 10%	CCT	Voltage	Base	Power Factor	CRI	Net Weight
DIV-CORN-27W	27W	Φ90 x H190 mm	4050lm	2700/3000/4000/5000/>6000K	AC100-277V, 50-60Hz	E26/E27 E39/EX39/E40	>0.95	CRI>80	0.77kg
DIV-CORN-36W	36W	Φ90 x H215 mm	5400lm	2700/3000/4000/5000/>6000K	AC100-277V, 50-60Hz	E26/E27 E39/EX39/E40	>0.95	CRI>80	0.87kg
DIV-CORN-45W	45W	Φ90 x H240 mm	6750lm	2700/3000/4000/5000/>6000K	AC100-277V, 50-60Hz	E26/E27 E39/EX39/E40	>0.95	CRI>80	0.95kg
DIV-CORN-54W	54W	Φ90 x H265 mm	8100lm	2700/3000/4000/5000/>6000K	AC100-277V, 50-60Hz	E26/E27 E39/EX39/E40	>0.95	CRI>80	1.0kg
DIV-CORN-60W	60W	Φ90 x H310 mm	9000lm	2700/3000/4000/5000/>6000K	AC100-277V, 50-60Hz	E26/E27 E39/EX39/E40	>0.95	CRI>80	1.25kg

LED Corn Light

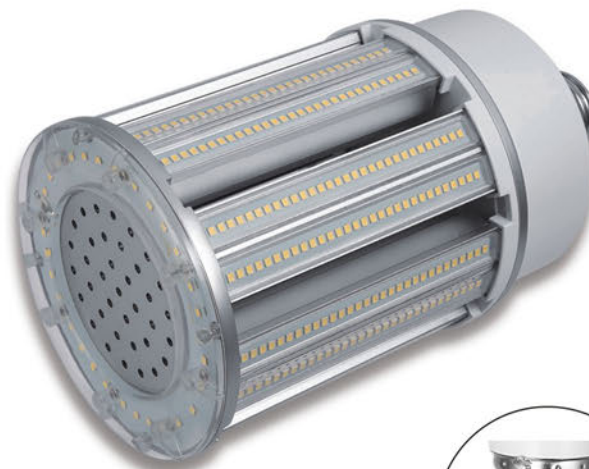

80W



100W



120W

Model No.	Power	Size	Lumen ± 10%	CCT	Voltage	Base	Power Factor	CRI	Net Weight
DIV-CORN-80W	80W	Φ140x H220 mm	12000lm	2700/3000/4000/5000/>6000K	AC100-277V, 50-60Hz	E39/EX39/E40	>0.95	CRI>80	1.65kg
DIV-CORN-100W	100W	Φ140 x H250 mm	15000lm	2700/3000/4000/5000/>6000K	AC100-277V, 50-60Hz	E39/EX39/E40	>0.95	CRI>80	1.90kg
DIV-CORN-120W	120W	Φ140 x H270 mm	18000lm	2700/3000/4000/5000/>6000K	AC100-277V, 50-60Hz	E39/EX39/E40	>0.95	CRI>80	2.05kg

LED PL Light



Epistar 2835 SMD



340° Rotating Base



Extruded aluminum housing, excellent heating dissipation



6W



8W



10W



12W



G24
21mm base



Gx24
15mm base



G23



Gx23



E27/E26



B22

Model No.	Power	Size	Lumen ± 10%	CCT	Voltage	LED Quantity	Power Factor	CRI	Net Weight
DIV-PL-6W	6W	120(L)*35(W)*35(H)mm	570lm	2700/3000/4000/5000/>6000K	AC100-277V	28pcs	>0.95	≥83	100g
DIV-PL-8W	8W	120(L)*35(W)*35(H)mm	800lm	2700/3000/4000/5000/>6000K	AC100-277V	40pcs	>0.95	≥83	100g
DIV-PL-10W	10W	160(L)*35(W)*35(H)mm	1050lm	2700/3000/4000/5000/>6000K	AC100-277V	48pcs	>0.95	≥83	120g
DIV-PL-12W	12W	160(L)*35(W)*35(H)mm	1200lm	2700/3000/4000/5000/>6000K	AC100-277V	60pcs	>0.95	≥83	120g





30W 270 degree

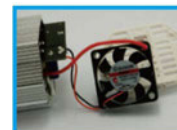

Built in Taiwan Sunon brand cooling fan. To ensure better heat dissipation



Samsung 2835SMD

Model No.	Power	Size	Lumen ± 10%	CCT	Voltage	LED Quantity	Power Factor	CRI	Net Weight
DIV-R7S-5W	5W	Φ25 x (L)78mm	500lm	2700/3000/4000/5000/>6000K	AC100-277V	24pcs	>0.9	≥83	50g
DIV-R7S-10W	10W	Φ25 x (L)118mm	1100lm	2700/3000/4000/5000/>6000K	AC100-277V	96pcs	>0.9	≥83	60g
DIV-R7S-12W	12W	Φ25 x (L)135mm	1350lm	2700/3000/4000/5000/>6000K	AC100-277V	120pcs	>0.9	≥83	100g
DIV-R7S-15W	15W	Φ25 x (L)189mm	1650lm	2700/3000/4000/5000/>6000K	AC100-277V	144pcs	>0.9	≥83	130g
DIV-R7S-30WA	30W	118(L)*55(W)*38(H)mm	3000lm	2700/3000/4000/5000/>6000K	AC170-265V	64pcs	>0.95	≥83	150g
DIV-R7S-30WB	30W	138(L)*55(W)*38(H)mm	3000lm	2700/3000/4000/5000/>6000K	AC170-265V	64pcs	>0.95	≥83	160g

LED G12



8W

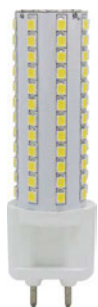

10WA



10WB



15W

Model No.	Power	Size	Lumen ± 10%	Base	CCT	Voltage	LED Quantity	Power Factor	CRI
DIV-G8.5-8W	8W	Φ30x90(L)mm	800lm	G8.5	2700/3000/4000/5000/>6000K	AC100-277V	84pcs	>0.95	≥83
DIV-G12-10WA	10W	Φ30x100(L)mm	1050lm	G12	2700/3000/4000/5000/>6000K	AC100-277V	108pcs	>0.95	≥83
DIV-G12-10WB	10W	Φ30x100(L)mm	1000lm	G12	2700/3000/4000/5000/>6000K	AC100-277V	96pcs	>0.95	≥83
DIV-G12-15W	15W	Φ30x130(L)mm	1500lm	G12	2700/3000/4000/5000/>6000K	AC100-277V	144pcs	>0.95	≥83

LED RIGID STRIPS



sbbe5

LINKABLE LED STRIPS FOR COVE AND UNDER-CABINET, ARCHITRECTORAL BACKLIGHTING AND MUCH MORE!



Item	Power	Lumen	Base	Voltage	Color temperature	Material	Certificate
DIV-T5-9W	9W	1000LM	T5 LED 3PIN Tube	85-264V	3000K/4000K/6000K	Aluminum alloy and PC	ETL
DIV-T5-12W	12W	1400LM	T5 LED 3PIN Tube	85-264V	3000K/4000K/6000K	Aluminum alloy and PC	ETL
DIV-T5-15W	15W	1600LM	T5 LED 3PIN Tube	85-264V	3000K/4000K/6000K	Aluminum alloy and PC	ETL

LED BULBS



DIV105



DIV106



DIV107



DIV108



DIV109

CAT#	VOLTAGE	POWER	LED TYPE	Lumin	CRI	CCT	BASE	DIMENSION
DIV105A	100V-240V AC	3W	3*1W CHIP	260Lm	>80	3200K/6500K	E27/E26/E14/B22	50*92mm
DIV105B	100V-240V AC	6W	3*2W CHIP	400Lm	>80	3200K/6500K	E27/E26/E14/B22	50*92mm
DIV106A	100V-240V AC	6W	3*2W CHIP	400Lm	>80	3200K/6500K	E27/E26	50*92mm
DIV107A	100V-240V AC	3W	48pcs SMD 0.1W CHIP	260Lm	>80	3200K/6500K	E27/E26	60*102mm
DIV107B	100V-240V AC	6W	48pcs SMD 0.2W CHIP	400Lm	>80	3200K/6500K	E27/E26	60*102mm
DIV108	120V AC/ 240V AC	3W	48pcs SMD 0.1W CHIP	260Lm	>80	3200K/6500K	E12/E14	32*100mm
DIV109	120V AC/ 240V AC	2W	30pcs SMD 0.1W CHIP	200Lm	>80	3200K/6500K	E12/E14	36*105mm
DIV111	120V AC/240V AC	2W	30pcs SMD 0.1W CHIP	260Lm	>80	3200K/6500K	E27/E26	60*102mm



GU10



MR16

DIVPS119-5

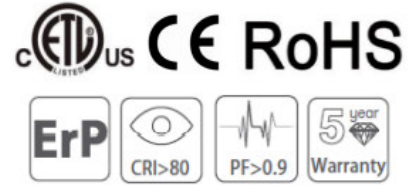

1. High rigidity and anti-corrosion surface.
2. Excellent heat dissipation (Die-casting Aluminum).
3. Exquisite appearance. High vibration resistance.
4. Ultra slim and easy installation.
5. Stable external driver - provides more security

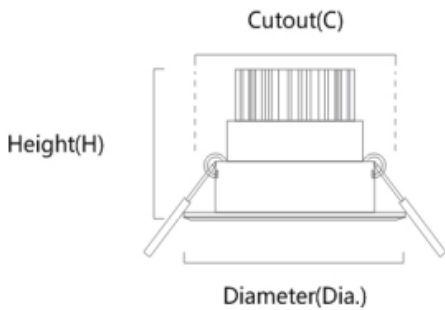

Size	Dia	H	C
2inch	85mm	65mm	70mm
3inch	108mm	83mm	90mm

*Unit = mm

*Cutout size can be +/-5mm

Dimension(MM)	D85xH65mm	D108xH83mm
LED quantity(Pc)	1pc COB	1pc COB
Power(w)	5w	7w
Cutout	70mm	90mm
Luminous flux(Lm)	450lm	630lm
Color Temp.	3000k-6000k	
Beam angle	30°, 60°	
Body	Aluminium	
Installation	Recess	
CRI	>80	
IP Rating	IP20	
Operating Temp.	-10°C to 40°C	
Input Voltage	100-240v AC	
Connection	Flex and Plug	

cETLus CE RoHS

DIVPS135



High rigidity and anti-corrosion surface.

Excellent heat dissipation (Die-casting Aluminum).

Exquisite appearance. High vibration resistance.

Ultra slim and easy installation.

Stable external driver - provides more security

***Also available in 3inch, 4inch, 5 and 6inch**

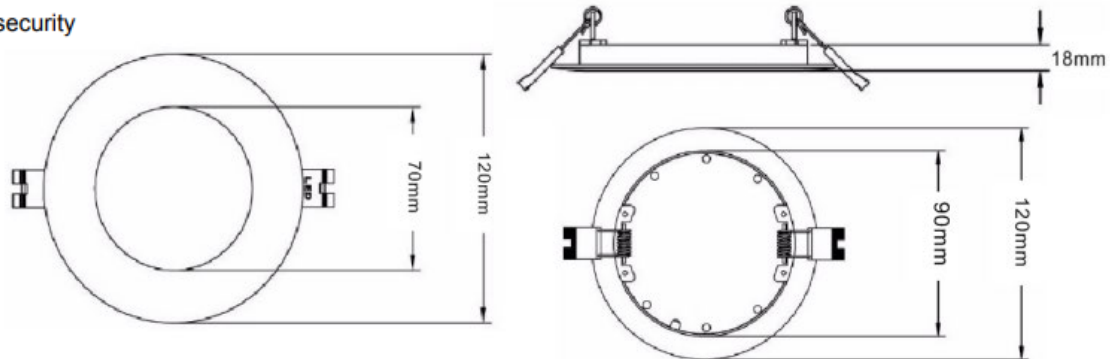

Dimension(MM)	D120xH18mm
LED quantity(Pc)	
Power(w)	8w
Cutout	90mm
Luminous flux(Lm)	720lm
Color Temp.	3000-6000k
Beam angle	120 degree
Body	aluminum
Installation	Recess
CRI	>80
IP Rating	IP22
Operating Temp.	'-20-40°C
Input Voltage	AC100-240v
Connection	Flex and Plug

P1

BASIC DATA

Product Number	Power Consumption Options (W)	Dimensions	CCT Options	Maximum Luminous Flux(lm)	Standard Version (Lm/W)	Premium Version (Lm/W)
DIV-20W DXYYZZ	10/15/20	1ft x 4ft	3500/4000/5000K	2,200/2,500	≥110	≥125
DIV-30W DXYYZZ	20/25/30	1ft x 4ft	3500/4000/5000K	3,300/3,750	≥110	≥125
DIV-40W DXYYZZ	20/30/40	1ft x 4ft	3500/4000/5000K	4,400/5,000	≥110	≥125

PHOTOMETRIC DATA

Rated Power	20-40W	Beam Angle	110°
Input Voltage	100-277/120-347VAC	CRI	≥80
Frequency	50/60 Hz	Dimming Function	0 - 10 V
Power Factor	>0.9	Operating Temperature	-20°C to 50°C



PHOTOMETRIC DIAGRAM

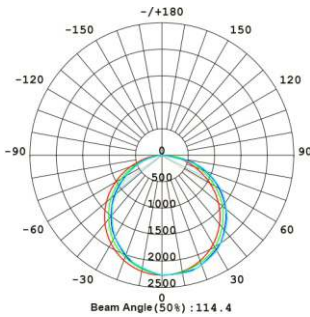

	Illuminance at a Distance	
	Center Beam fc	Beam Width
17.0ft	7.80 fc	52.3 ft 52.6 ft
34.0ft	1.95 fc	104.5 ft 105.1 ft
51.0ft	0.87 fc	156.8 ft 157.7 ft
68.0ft	0.49 fc	209.1 ft 210.3 ft
85.0ft	0.31 fc	261.3 ft 262.8 ft
102.0ft	0.22 fc	313.6 ft 315.4 ft

■ Vert. Spread: 113.9°
■ Horiz. Spread: 114.2°

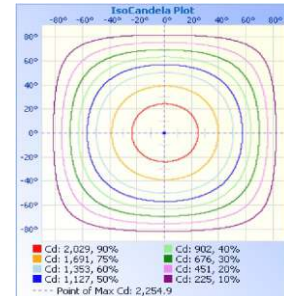

50W

BASIC DATA

P4

Product Number	Power Consumption Options (W)	Dimensions	CCT Options	Maximum Luminous Flux(lm)	Standard Version (Lm/W)	Premium Version (Lm/W)
DIV-20W DXYYZZ	10/15/20	2ft x 2ft	3500/4000/5000K	2,200/2,500	≥110	≥125
DIV-30W DXYYZZ	20/25/30	2ft x 2ft	3500/4000/5000K	3,300/3,750	≥110	≥125
DIV-40W DXYYZZ	20/30/40	2ft x 2ft	3500/4000/5000K	4,400/5,000	≥110	≥125

PHOTOMETRIC DATA

Rated Power	20-40W	Beam Angle	110°
Input Voltage	100-277/120-347VAC	CRI	≥80
Frequency	50/60 Hz	Dimming Function	0 - 10 V
Power Factor	>0.9	Operating Temperature	-20°C to 50°C



PHOTOMETRIC DIAGRAM

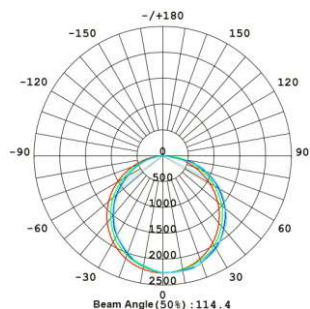

	Illuminance at a Distance	
	Center Beam fc	Beam Width
17.0ft	7.80 fc	52.3 ft 52.6 ft
34.0ft	1.95 fc	104.5 ft 105.1 ft
51.0ft	0.87 fc	156.8 ft 157.7 ft
68.0ft	0.49 fc	209.1 ft 210.3 ft
85.0ft	0.31 fc	261.3 ft 262.8 ft
102.0ft	0.22 fc	313.6 ft 315.4 ft

■ Vert. Spread: 113.9°
■ Horiz. Spread: 114.2°

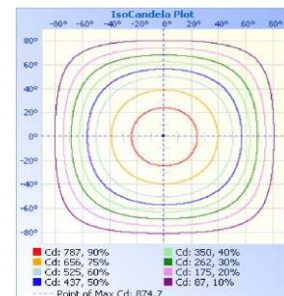

60W

P7

BASIC DATA

Product Number	Power Consumption Options (W)	Dimensions	CCT Options	Maximum Luminous Flux(lm)	Standard Version (Lm/W)	Premium Version (Lm/W)
DIV-40W DXYYZZ	20/30/40	2ft x 4ft	3500/4000/5000K	4,400/5,000	≥110	≥125
DIV-50W DXYYZZ	30/40/50	2ft x 4ft	3500/4000/5000K	5,500/6,250	≥110	≥125
DIV-60W DXYYZZ	40/50/60	2ft x 4ft	3500/4000/5000K	6,600/7,500	≥110	≥125

PHOTOMETRIC DATA

Rated Power	40/50/60W	Beam Angle	110°
Input Voltage	100-277/120-347VAC	CRI	≥80
Frequency	50/60 Hz	Dimming Function	0 - 10 V
Power Factor	>0.9	Operating Temperature	-20°C to 50°C



PHOTOMETRIC DIAGRAM

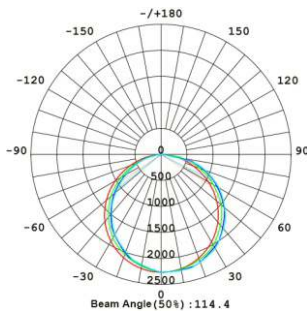

	Center Beam fc	Beam Width	
17.0ft	9.77 fc	52.3 ft	52.4 ft
34.0ft	2.44 fc	104.6 ft	104.9 ft
51.0ft	1.09 fc	156.8 ft	157.3 ft
68.0ft	0.61 fc	209.1 ft	209.7 ft
85.0ft	0.39 fc	261.4 ft	262.1 ft
102.0ft	0.27 fc	313.7 ft	314.6 ft

■ Vert. Spread: 113.9°
■ Horiz. Spread: 114.1°

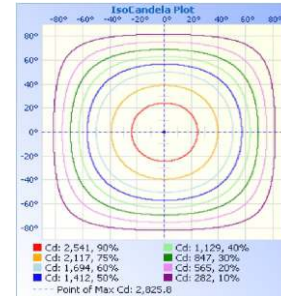

60W

MOUNTING OPTION

Recessed Mount

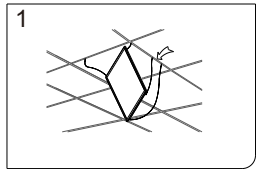

1. Safety wire design available.

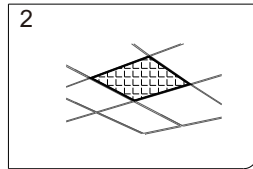

2. Perfectly to replace traditional fluorescent troffer.

Pendant Mount

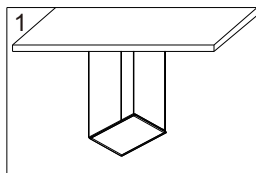

1. Wire pendant installation.

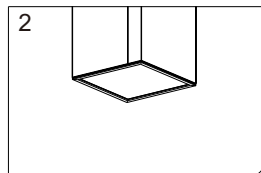

2. Conveniently to adjust the luminaire's height

Surface Mount

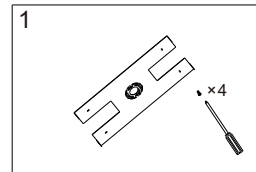

1. Tighten the installation bracket on the ceiling board

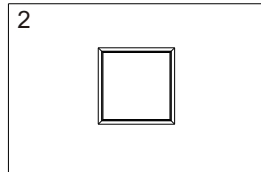

2. Easily to match the LED panel with bracket.

DIMENSION

Unit: mm/inch

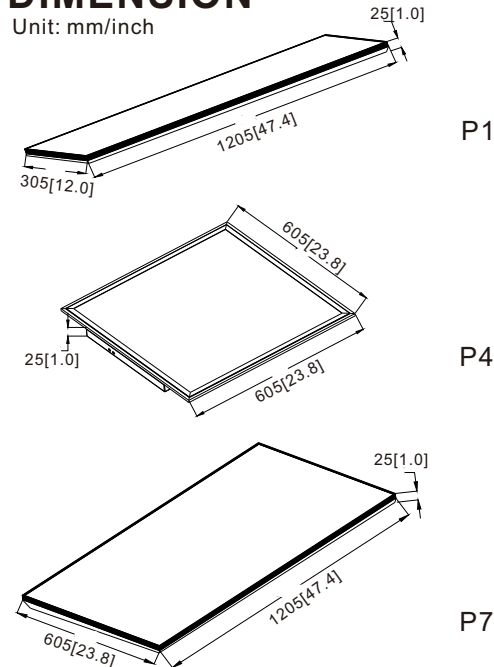

Product Code	Product Size	Packing Dimension	PCS/ Carton	N.W(kg)	G.W(kg)
P1	1' x 4'	1270*370*190mm	4PCS	4.15	5.5
P4	2' x 2'	670*670*190mm	4PCS	4.06	5.3
P7	2' x 4'	1270*670*190mm	4PCS	8.10	10.3

ORDERING GUIDE

Px	15W...75W	DXYYZZ
Series Code	Wattage	D: Directly Beam X: Can be D for Power and CCT Regulation Function, or S for Power Regulation Function, or N for Normal Type YY: Color Temperature of LED. 27=2700K, 35=3500K, 65=6500K, 00=Color Tunable ZZ: Input Voltage. 27 Represents 120-277VAC, 34 Represents 120-347VAC

T8 LED Tubes

(Models available functioning with and without ballast)



RoHS

LM80

IP65



5 years warranty

50.000 HRS



VARIABLE RE-ADJUSTABLE WATTAGE/BRIGHTNESS and FIXED WATTAGE LED T8 RETROFIT TUBES

Item	Product code	Picture	Size	Lumen	Description
T8 Dual Model LED tube (work with and without ballast)					
Dual Model LED tube (UL type A+B)	DIVT8-P12W1200 BIXX Dual Model tube		4 ft	1680 lm	Nano Plastic housing Internal driver AC100-277V
	DIV-8-P15W1200 BIXX Dual Model tube		4 ft	1950 lm	
	DIV18-P18W1200 BIXX Dual Model tube		4 ft	2340 lm	
	DIVT8-0W600 BIXX Dual Model tube		2 ft	1400 lm	Oval Aluminum Housing Internal driver AC100-277V
	DIV18-15W600 BIXX Dual Model tube		2 ft	1950 lm	
	DIVT8-15W900 BIXX Dual Model tube		3 ft	1950 lm	
	DIVT8-12W1200 BIXX Dual Model tube		4 ft	1680 lm	
	DIVT8-15W1200 BIXX Dual Model tube		4 ft	1950 lm	
	DIVT8-18W1200 BIXX Dual Model tube		4 ft	2340 lm	
	DIVT8-20W1200 BIXX Dual Model tube		4 ft	2600 lm	
T8 Dual Model LED tube (work with and without ballast) Round Housing					
Dual Model LED tube (UL type A+B) Single CCT and Single Wattage	DIVZY-T8-15W600 BIXX		2 ft	1950 lm	Circular Aluminum Housing Internal driver AC100-277V
	DIVZY-T8-10W1200 BIXX		4 ft	1300 lm	
	DIVZY-T8-12W1200 BIXX		4 ft	1680 lm	
	DIVZY-T8-15W1200 BIXX		4 ft	1950 lm	
	DIVZY-T8-18W1200 BIXX		4 ft	2340 lm	
	DIVZY-T8-20W1200 BIXX		4 ft	2600 lm	
LED tube (UL type A+B) Single CCT and Adjustable Wattage	DIVZY-T8-15W/12W/10W1200 BIXX		4 ft	13000 lm-1950 lm	Circular Aluminum Housing Internal driver AC100-277V
	DIVZY-T8-20W/18W/15W1200 BIXX		4 ft	1950 lm-2600 lm	

LED Tri-proof Light



RUGGED WEATHERPROOF FIXTURES



Model No.	Power	Lumen $\pm 10\%$	Input Voltage	CCT	CRI	IP Grade	Dimensions
DIV-Tri-Proof-20W	20W	2400lm	AC200-240V AC100-277V	2700/3000/4000/5000/>6000K	>80	IP65	600x80x72mm
DIV-Tri-Proof-30W	30W	3600lm	AC200-240V AC100-277V	2700/3000/4000/5000/>6000K	>80	IP65	600x80x72mm
DIV-Tri-Proof-40W	40W	4800lm	AC200-240V AC100-277V	2700/3000/4000/5000/>6000K	>80	IP65	1200x80x72mm
DIV-Tri-Proof-50W	50W	6000lm	AC200-240V AC100-277V	2700/3000/4000/5000/>6000K	>80	IP65	1200x80x72mm
DIV-Tri-Proof-50W	50W	6000lm	AC200-240V AC100-277V	2700/3000/4000/5000/>6000K	>80	IP65	1500x80x72mm
DIV-Tri-Proof-60W	60W	7200lm	AC200-240V AC100-277V	2700/3000/4000/5000/>6000K	>80	IP65	1500x80x72mm
DIV-Tri-Proof-100W	100W	12000lm	AC200-240V AC100-277V	2700/3000/4000/5000/>6000K	>80	IP65	1800x110x86mm
DIV-Tri-Proof-120W	120W	14400lm	AC200-240V AC100-277V	2700/3000/4000/5000/>6000K	>80	IP65	2400x110x86mm

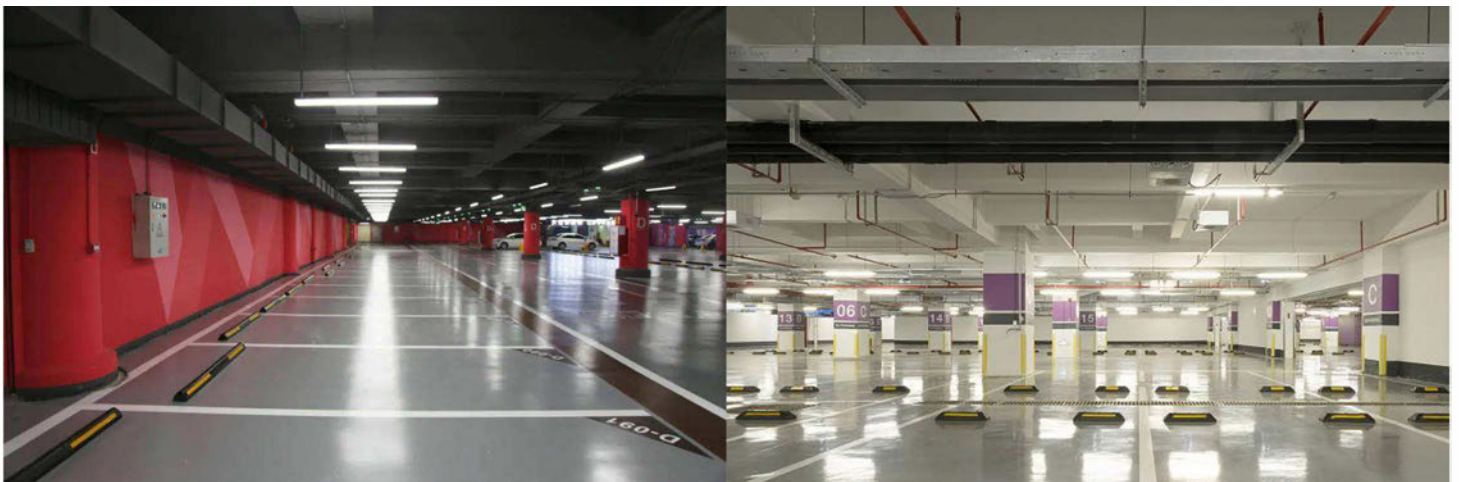

LED 2G11 Tube

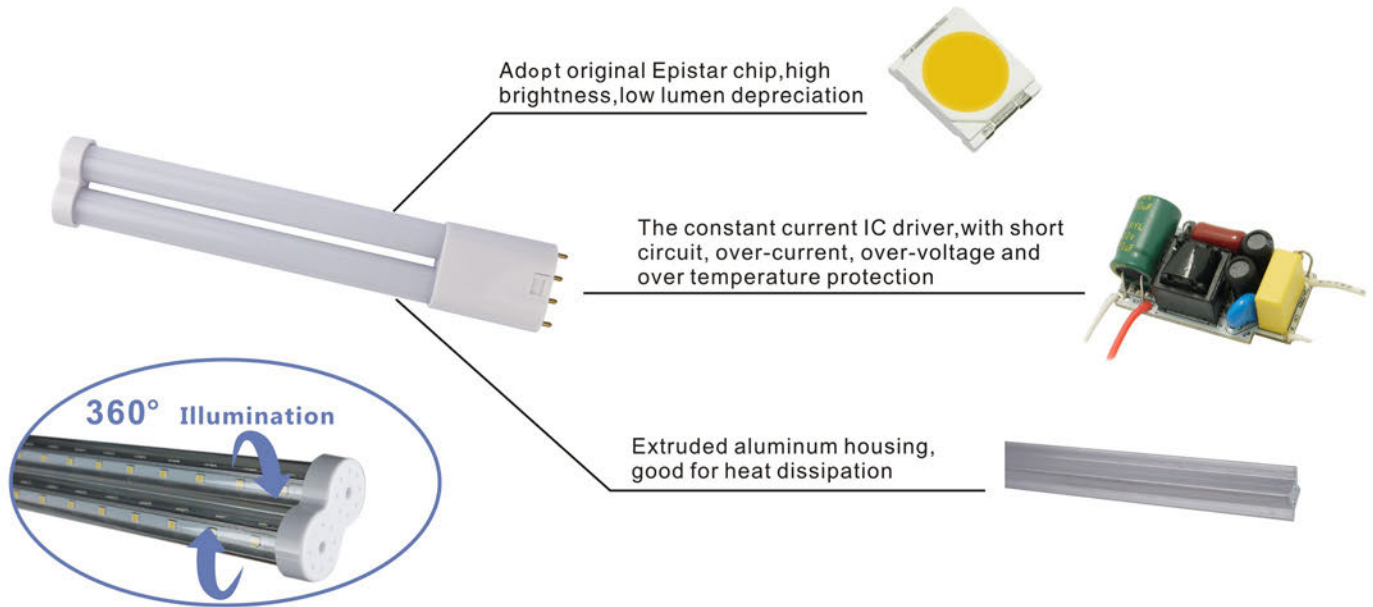

Model No.	Power	Size	Lumen $\pm 10\%$	Base	CCT	Voltage	Power Factor	CRI	Net Weight
DIV-2G11-9W	9W	225(L)*41(W)*18(H)mm	1000lm	2G11	2700/3000/4000/5000/>6000K	AC100-277V	>0.95	≥ 83	180g
DIV-2G11-15W	15W	320(L)*41(W)*18(H)mm	1800lm	2G11	2700/3000/4000/5000/>6000K	AC100-277V	>0.95	≥ 83	240g
DIV-2G11-18W	18W	410(L)*41(W)*18(H)mm	2100lm	2G11	2700/3000/4000/5000/>6000K	AC100-277V	>0.95	≥ 83	240g
DIV-2G11-23W	23W	535(L)*41(W)*18(H)mm	2700lm	2G11	2700/3000/4000/5000/>6000K	AC100-277V	>0.95	≥ 83	330g

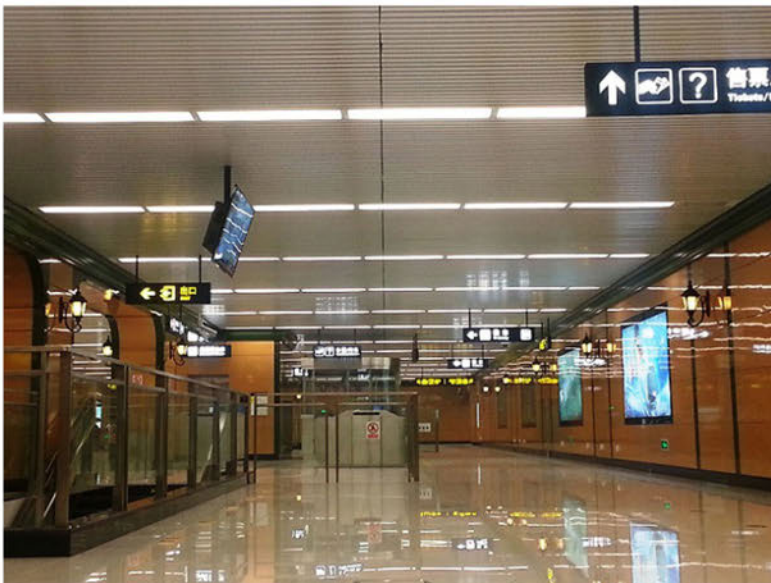

LED S19/S14 Tube



S19



S14d



S14s

Model No.	Power	Equivalent Wattage	Size	Lumen \pm 10%	Base	CCT	Voltage	Beam Angle	Power Factor	CRI
DIV-S19-9W	9W	60W	Φ 38x311(L)mm	806lm	S19	2700/3000/4000/5000/>6000K	AC100-277V	330°	>0.55	\geq 83
DIV-S14-4W	4W	33W	Φ 30x300(L)mm	360lm	S14s S14d	2700/3000/4000/5000/>6000K	AC100-277V	200°	>0.55	\geq 83
DIV-S14-5W	5W	39W	Φ 30x300(L)mm	450lm	S14s S14d	2700/3000/4000/5000/>6000K	AC100-277V	200°	>0.55	\geq 83
DIV-S14-7W	7W	48W	Φ 30x500(L)mm	600lm	S14s S14d	2700/3000/4000/5000/>6000K	AC100-277V	200°	>0.55	\geq 83
DIV-S14-8W	8W	54W	Φ 30x500(L)mm	700lm	S14s S14d	2700/3000/4000/5000/>6000K	AC100-277V	200°	>0.55	\geq 83
DIV-S14-16W	16W	100W	Φ 30x1000(L)mm	1450lm	S14s S14d	2700/3000/4000/5000/>6000K	AC100-277V	200°	>0.9	\geq 83

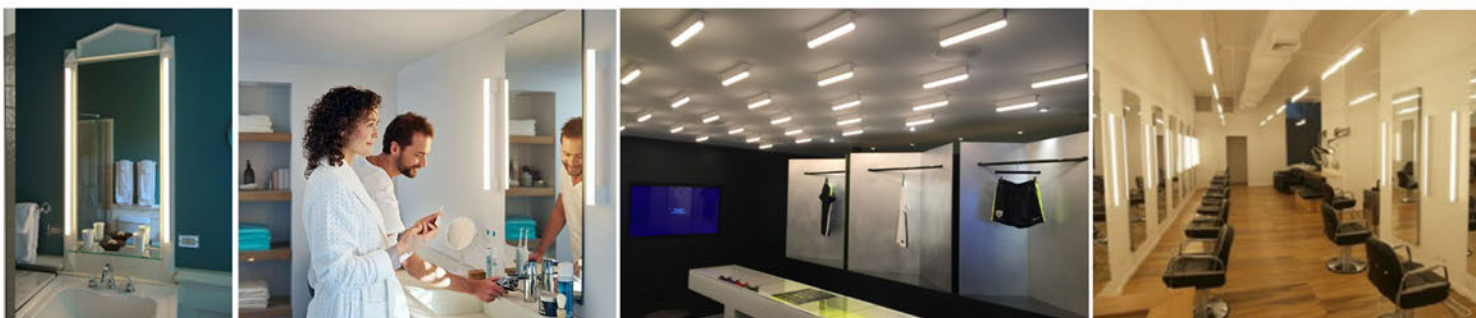

LED Linear High Bay Light

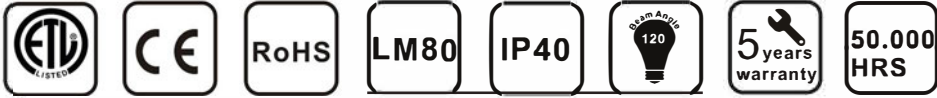

Model No.	Power	Lumen \pm 10%	Input Voltage	CCT	CRI	IP Grade	Dimensions
DIV-LH-W100-S1	100W	13000lm	AC100-277V	2700/3000/4000/5000/>6000K	>80	IP40	625x205x48mm
DIV-LH-W150-S1	150W	19500lm	AC100-277V	2700/3000/4000/5000/>6000K	>80	IP40	625x325x48mm
DIV-LH-W200-S1	200W	26000lm	AC100-277V	2700/3000/4000/5000/>6000K	>80	IP40	900x325x48mm
DIV-LH-W240-S1	240W	31200lm	AC100-277V	2700/3000/4000/5000/>6000K	>80	IP40	900x325x48mm
DIV-LH-W320-S1	320W	41600lm	AC100-277V	2700/3000/4000/5000/>6000K	>80	IP40	1200x325x48mm

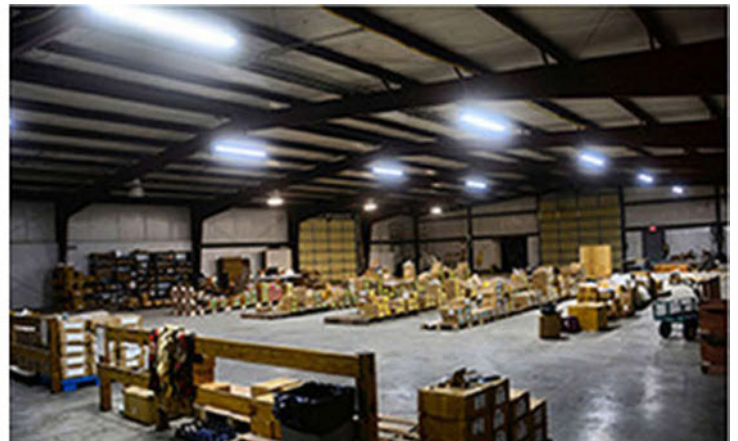

LED UFO High Bay Light



Patent
DLC Premium
0-10V Dimmable

CCT & Wattage Selectable

Model	3 Wattage Selectable			2 CCT Selectable
	A	B	C	
150W	150W	100W	80W	6000K/5000K/4000K/3000K
200W	200W	150W	100W	
240W	240W	200W	150W	



Model No.	Power	Lumen ± 10%	Voltage	Beam Angle	CCT	CRI	IP Grade	Dimensions
DIV-UFO-W100-S6	100W	15000lm	AC100-277V AC200-528V	60° 90° 120°	2700/3000/4000/5000/>6000K	>80	IP65	260x260x163mm
DIV-UFO-W150-S6	150W	22500lm	AC100-277V AC200-528V	60° 90° 120°	2700/3000/4000/5000/>6000K	>80	IP65	260x260x163mm
DIV-UFO-W200-S6	200W	30000lm	AC100-277V AC200-528V	60° 90° 120°	2700/3000/4000/5000/>6000K	>80	IP65	300x300x177mm
DIV-UFO-W240-S6	240W	36000lm	AC100-277V AC200-528V	60° 90° 120°	2700/3000/4000/5000/>6000K	>80	IP65	300x300x177mm



90° PC reflector



Emergency battery



Micro-wave sensor

LED UFO High Bay Light



Model No.	Power	Lumen \pm 10%	Voltage	Beam Angle	CCT	CRI	IP Grade	Dimensions
DIV-UFO-100W-S6	100W	13000lm	AC100-277V	120°	2700/3000/4000/5000/>6000K	>80	IP65	280x280x163mm
DIV-UFO-150W-S6	150W	19500lm	AC100-277V	120°	2700/3000/4000/5000/>6000K	>80	IP65	280x280x163mm

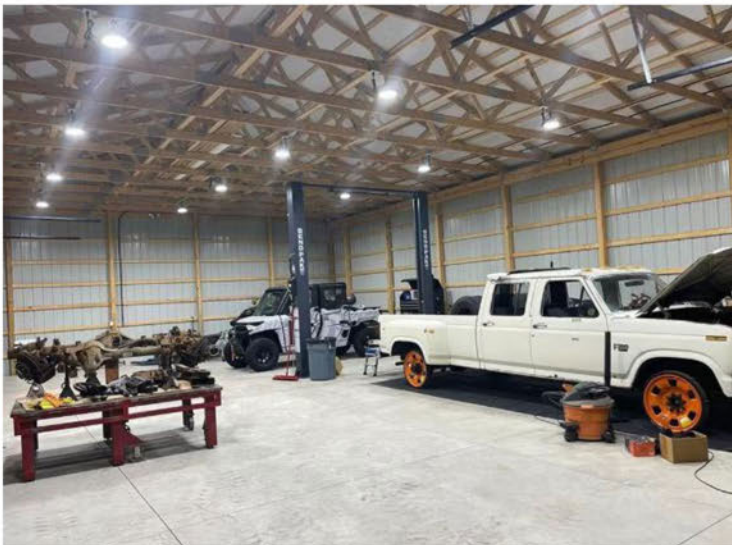

LED UFO High Bay Light



300W

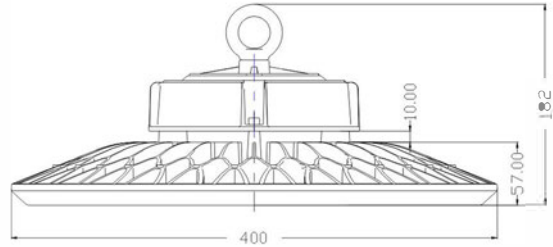

400W/500W

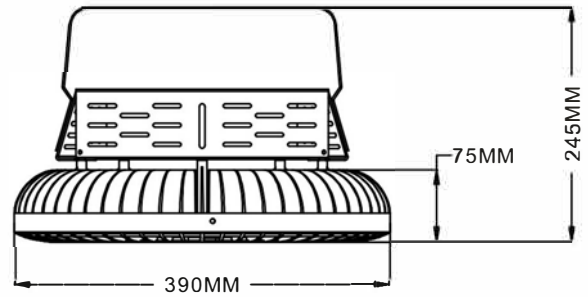

Model No.	Power	Lumen $\pm 10\%$	Voltage	Beam Angle	CCT	CRI	IP Grade	Dimensions
DIV-UFO-W300-S6	300W	45000lm	AC100-277V AC200-528V	60° 90° 120°	2700/3000/4000/5000/>6000K	>80	IP65	440x440x182mm
DIV-UFO-W400-S6	400W	60000lm	AC100-277V AC200-528V	45° 80° 120°	2700/3000/4000/5000/>6000K	>80	IP65	390x390x245mm
DIV-UFO-W500-S6	500W	75000lm	AC100-277V AC200-528V	45° 80° 120°	2700/3000/4000/5000/>6000K	>80	IP65	390x390x245mm



LED Wall Pack Light



INTEGRATED PHOTOCELL



Built-in photocell sensor to automatically turn on at night and off during the day for increased efficiency

Model No.	Power	Lumen \pm 10%	Input Voltage	CCT	CRI	IP Grade	Dimensions
DIV-WPK-W40-S7A	40W	5200lm	AC100-277V	2700/3000/4000/5000/>6000K	>80	IP65	332x235.5x172mm
DIV-WPK-W60-S7A	60W	7800lm	AC100-277V	2700/3000/4000/5000/>6000K	>80	IP65	332x235.5x172mm
DIV-WPK-W100-S7A	100W	13000lm	AC100-277V	2700/3000/4000/5000/>6000K	>80	IP65	332x235.5x172mm
DIV-WPK-W120-S7A	120W	15600lm	AC100-277V	2700/3000/4000/5000/>6000K	>80	IP65	332x235.5x172mm



LED Post Top Light



Model No.	Power	Lumen \pm 10%	Voltage	Beam Angle	CCT	CRI	IP Grade	Dimensions
DIV-HB01-W50-S4-XX	50W	7500lm	AC100-277V AC200-528V	60° 90° 120°	2700/3000/4000/5000/>6000K	>80	IP65	390x390x245mm
DIV-HB01-W80-S4-XX	80W	12000lm	AC100-277V AC200-528V	60° 90° 120°	2700/3000/4000/5000/>6000K	>80	IP65	390x390x245mm
DIV-HB01-W100-S4-XX	100W	15000lm	AC100-277V AC200-528V	60° 90° 120°	2700/3000/4000/5000/>6000K	>80	IP65	390x390x245mm
DIV-HB01-W150-S4-XX	150W	22500lm	AC100-277V AC200-528V	60° 90° 120°	2700/3000/4000/5000/>6000K	>80	IP65	390x390x245mm
DIV-HB01-W200-S4-XX	200W	30000lm	AC100-277V AC200-528V	60° 90° 120°	2700/3000/4000/5000/>6000K	>80	IP65	390x390x245mm



LED Shoebox Light



Model No.	Power	Lumen $\pm 10\%$	Input Voltage	Beam Angle	CCT	CRI	IP Grade	Dimensions
DIV-SL-W75-S2	75W	9750lm	AC100-277V	Type II III IV V	2700/3000/4000/5000/>6000K	>80	IP65	600X370X150mm
DIV-SL-W100-S2	100W	13000lm	AC100-277V	Type II III IV V	2700/3000/4000/5000/>6000K	>80	IP65	600X370X150mm
DIV-SL-W150-S2	150W	19500lm	AC100-277V	Type II III IV V	2700/3000/4000/5000/>6000K	>80	IP65	600X370X150mm
DIV-SL-W200-S2	200W	26000lm	AC100-277V	Type II III IV V	2700/3000/4000/5000/>6000K	>80	IP65	700X370X150mm
DIV-SL-W300-S2	300W	39000lm	AC100-277V	Type II III IV V	2700/3000/4000/5000/>6000K	>80	IP65	840X370X160mm



LED Flood Light



Model No.	Power	Lumen $\pm 10\%$	Input Voltage	Beam Angle	CCT	CRI	Dimensions
DIV-FL-50W	50W	6000lm	AC100-277V	60° 90° 120°	2700/3000/4000/5000/>6000K	>80	310x220x50mm
DIV-FL-80W	80W	9600lm	AC100-277V	60° 90° 120°	2700/3000/4000/5000/>6000K	>80	354x245x55mm
DIV-FL-100W	100W	12000lm	AC100-277V	60° 90° 120°	2700/3000/4000/5000/>6000K	>80	402x295x60mm
DIV-FL-150W	150W	18000lm	AC100-277V	60° 90° 120°	2700/3000/4000/5000/>6000K	>80	430x330x60mm
DIV-FL-200W	200W	24000lm	AC100-277V	60° 90° 120°	2700/3000/4000/5000/>6000K	>80	470x360x60mm
DIV-FL-300W	300W	36000lm	AC100-277V	60° 90° 120°	2700/3000/4000/5000/>6000K	>80	565x457x65mm
DIV-FL-450W	450W	54000lm	AC100-277V	60° 90° 120°	2700/3000/4000/5000/>6000K	>80	585x559x70mm





divVALI
LED LIGHTING & DESIGN



Products for Hazardous and Harsh Locations

Safe/Reliable/Efficient

5555 Westminster Ave, Suite 414,
Montreal, Quebec, Canada, H4W-2J2,
ph 514-952-9533, f 514-439-1393





Potable Self standing

1-10W

Zone 2, Zone 22



Portable Self standing LG

Strong Light: 2W
Work Light: 1W

Class 1 Division 1&2
Zone 0, 1, 2



Series WKG

Strong Light: 2W
Work Light: 1W

Zone 0,1,2,
Zone 20. 21,22



Gas Detector IN01

DIVXINO1-A/B/C/D

Working Temperature:
-60°C to 70°C / -60°C to 85°C
-76°F to 158°F / -76°F to 185°F

Voltage: DC24V

Degree of Protection: IP66

Class 1 Division 1&2
Zone 1&2,
Zone 21&22



Sensor

DIVXINO2-MS/OS/MO

Working Temperature:
-30°C~60°C(-22°F~140°F)

Voltage: AC120-277V
AC120-347V

Degree of Protection: IP66

Class 1 Division 2
Zone 1&2, Zone 21



**lighting control switch
(motion sensor)**

DIVXINO1-B-MS/OS/MO

Voltage: AC120-277V, 50Hz

Detection Zone:
Max. (D x H): 16m x 15m

Degree of Protection: IP66/67

Class 1 Division 1&2
Zone 1&2, Zone 21&22



**Enclosure for lighting control
switch (motion sensor)**

Degree of Protection: IP66/67

Class 1 Division 1&2
Zone 1&2, Zone 21&22



Distribution Equipment

DIVX-PD61

Voltage: Max. AC1000V
50/60 HZ

Current:1200A

Degree of Protection: IP66
Zone 1&2, Zone 21&22



Distribution Equipment

DIV-PD62

Voltage: Max. AC1000V
50/60 HZ

Current:1200A

Degree of Protection: IP66
Zone 1&2, Zone 21&22



Series A/A2/A3/A4

A2: 20-60W;
A: 80-100W;
A3: 150-200W;
A4: 250-400W

Class I Division 2
Zone 1&2, Zone 21&22



Series A5/A6

A5: 50-240W;
A6: 50-120W

Zone 1&2,
Zone 21&22



Series A7/A8

A7: 100-480W;
A8: 100-240W

Zone 1&2,
Zone 21&22



Series A9/A10

A9: 50-240W;
A10: 50-120W

Zone 1&2,
Zone 21&22



Series B/B2/B3/B4

B2: 20-40W;
B: 60-80W;
B3: 100-200W;
B4: 250-400W

Class I Division 2
Zone 1&2, Zone 21&22

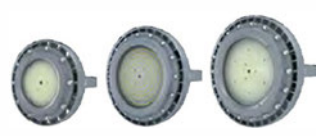

Series C/C2/C3

C2: 20-80W;
C: 100-200W;
C3: 200-280W

Class I Division 1&2
Zone 1&2, Zone 21&22

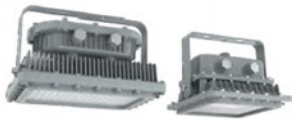

Series D/D2

D2: 20-80W;
D: 100-200W

Class I Division 1&2
Zone 1&2, Zone 21&22



Series D3/D4

D3: 100/150/200/220W;
D4: 38/58/68W

Class I Division 1&2
Zone 1&2, Zone 21&22



Series G

10-50W

Class I Division 1&2
Zone 1&2, Zone 21&22



Series O

10-40W;

Class I Division 2
Zone 1&2, Zone 21&22



Series Q1/Q2

Q1: 20-80W;
Q2: 100-200W

Zone 2, Zone 21&22



Series S1/S2

S1: 20-80W;
S2: 100-200W

Zone 1&2, Zone 21,22



Series L&LL

L:3-30W;
LL:3-30W

Class I Division 1&2
Zone 1&2, Zone 21&22



Series R2/R4

R2: 10-40W;
R4: 10-60W

Class I Division 2
Zone 1&2, Zone 21&22



Series RL2/RL4

RL2: 10-40W
RL4: 20-60W

Class I Division 2
Zone 1&2, Zone 21&22



Series H2/H4

H2: 20-40W;
H4: 40-80W

Class I Division 2
Zone 2, Zone 21&22



Series I2/I4

I2: 20-60W;
I4: 60-120W

Class I Division 1&2
Zone 1&2, Zone 21&22



Series STA1/STA2

STA1: 200-250W
STA2: 10-150W

Class I Division 2
Zone 2, Zone 21&22



Series STA4/STA5

STA4: Max.80W
STA5: Max.130W

Zone 1&2, Zone 21&22



Series FLA1/FLA2

FLA1: 20-200W; 20-150W
FLA1e: 20-150W; 20-100W
FLA2: 20-60W
FLA2e: 20-60W; 20-100W

Class I Division 1
Zone 1&2, Zone 21&22



Series FLA3

FLA3: 500W(MAX.)

Zone 1&2, Zone 21&22



Series FLB

0.6m: 12W/15W/18W
1.2m: 25W/30W/36W/40W

Zone 1&2,
Zone 21&22



Series FLC

FLC2: 20W/40W
FLC4: 50W/80W
FLC5: 50W/80W

Zone 1&2,
Zone 21&22



Series FLD

1x2: 40W
1x4: 40W/60W
2x2: 40W/60W/80W
2x4: 60W/80W/100W/120W

Class 1 Division 2
Zone 1, Zone 2



Series FLE

FLE2: 20W/40W
FLE4: 50W/80W
FLE5: 50W/80W

Class I Division 2
Zone 1&2, Zone 21&22



Series FLF

FLF2: 20W/40W
FLF4: 50W/80W
FLF5: 50W/80W

Class I Division 2
Zone 2, Zone 21&22



Series ES01

Exit Light: 3-10W
Illuminating Light: 3-15W

Zone 1&2, Zone 21&22



Series ES02 A1

5W/8W/10W
15W/16W/20W/24W

Zone 1&2, Zone 21&22



Series ES02 B1

7-20W

Zone 1&2, Zone 21&22



Series ES02 B2/B3

5W

Zone 1&2, Zone 21&22



Series ES02 B4/B5

Head Light: 15W Max.
Exit Sign: 5W Max.

Zone 1&2, Zone 21&22



Series ES02 C1

3W/5W/10W

Zone 1&2, Zone 21&22



Series ES02 C2/C3

Junction Box &
Emergency Backup Box

Zone 1&2, Zone 21&22



Series ES02 D1

3W/5W/10W

Zone 1&2, Zone 21&22



OEM Only

Series ES03 A2/A3

A2: 3W/5W/8W/10W
A3: 3W/5W/8W/10W

Class I Division 1&2



OEM Only

Series ES03 C1/A1

C1: 3W/5W/10W
A1: 3W/5W/8W/10W

Class I Division 1&2



Series V

Max.5W

Class I Division 2
Zone 1&2, Zone 21&22



Type text here

Series J

Max.5W

Class I Division 1&2



Series MV01

Strong Light: 19.5W
Work Light: 10W

Class I Division 1
Zone 0, 1, 2

Stainless Steel



Series SS1

30/40/50W

Class 1 Division 1&2
Zone 1&2
Zone 21&22

Stainless Steel



Series SS2

30/40/50W

Class 1 Division 1&2
Zone 1&2
Zone 21&22

Iron Housing



Signal Lamp

18W

Class 1 Division 1&2
Zone 1&2
Zone 21&22



Series CPA

60-150W

Zone 2, Zone 21&22



Series SFL

20W

Zone 1&2



Series AL

7W

Zone 1&2



OEM Only

Series ES03 C2/A4

EX-PD61-YJ01 ES03C2
EX-PD61-YJ01 ES03A4

Class I Division 1&2



Series EX-IL

5W/8W/9W/10W/12W

Zone 1&2, Zone 21&22



Series HB-D

D1: 100-150W
D2: 200-300W;
D3: 300-450W;
D4: 400-600W

Working Temperature:
-40°C ~ +70°C; -40°F ~ +158°F



Divvali Lighting Inc.

Address: 5555 Westminster Ave Ste 415,
Montreal, Quebec, H4W 2J2, Canada

TEL: 1-888-439-1398

Local: 514-439-1390 / 514-952-9533

Email: info@divvalilighting.com

Web: www.divvalilighting.com